



AQUARIUM SERIES FILTER PUMPS



ALBsalt

- IP55 waterproof standard.
- Big flow rate.
- Maximum working pressure up to 6kg/cm².
- 316 stainless steel shaft.
- 316 spring+Italian graphite+rubber mechanical seal.
- Motor speed 1450 r.p.m
- Suitable for maximum hot water temperature up to 70°C.



Appearance and design patented, counterfeiting not allowed!
 Patent No.: CN201830218633.9

Suitable for sea water, Low noise, high flow rate, high temperature and high pressure resistance.

Specification and size:

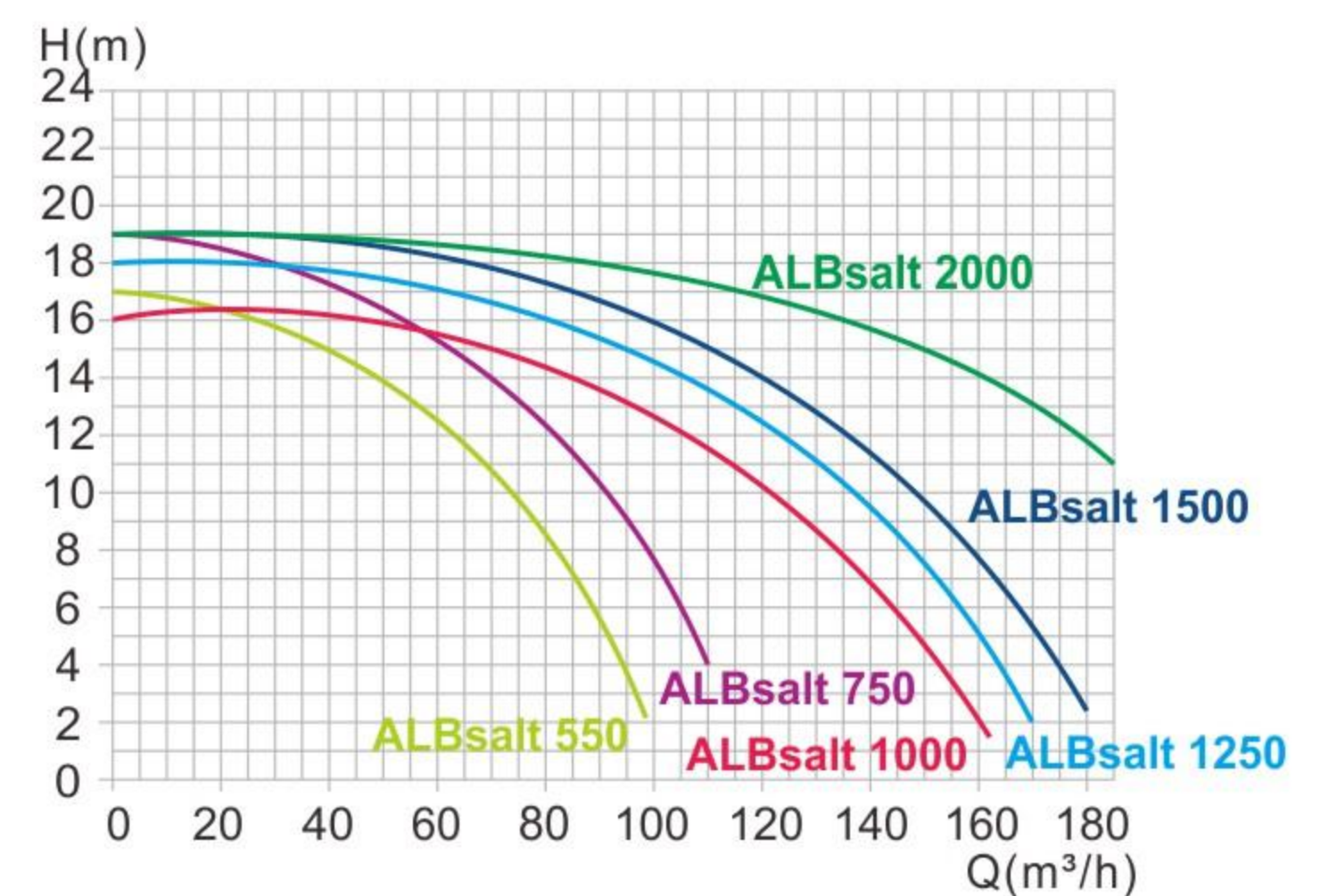
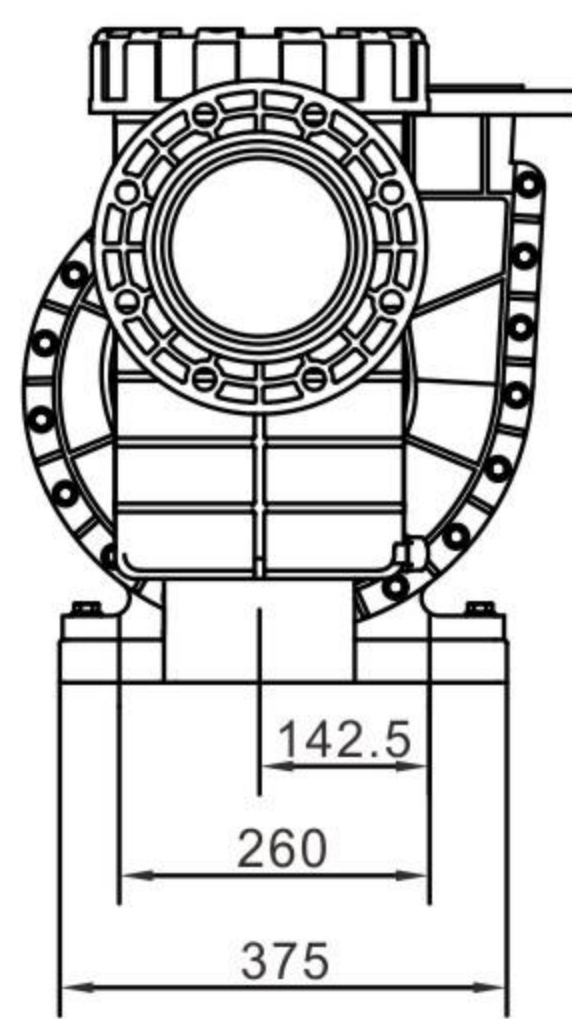
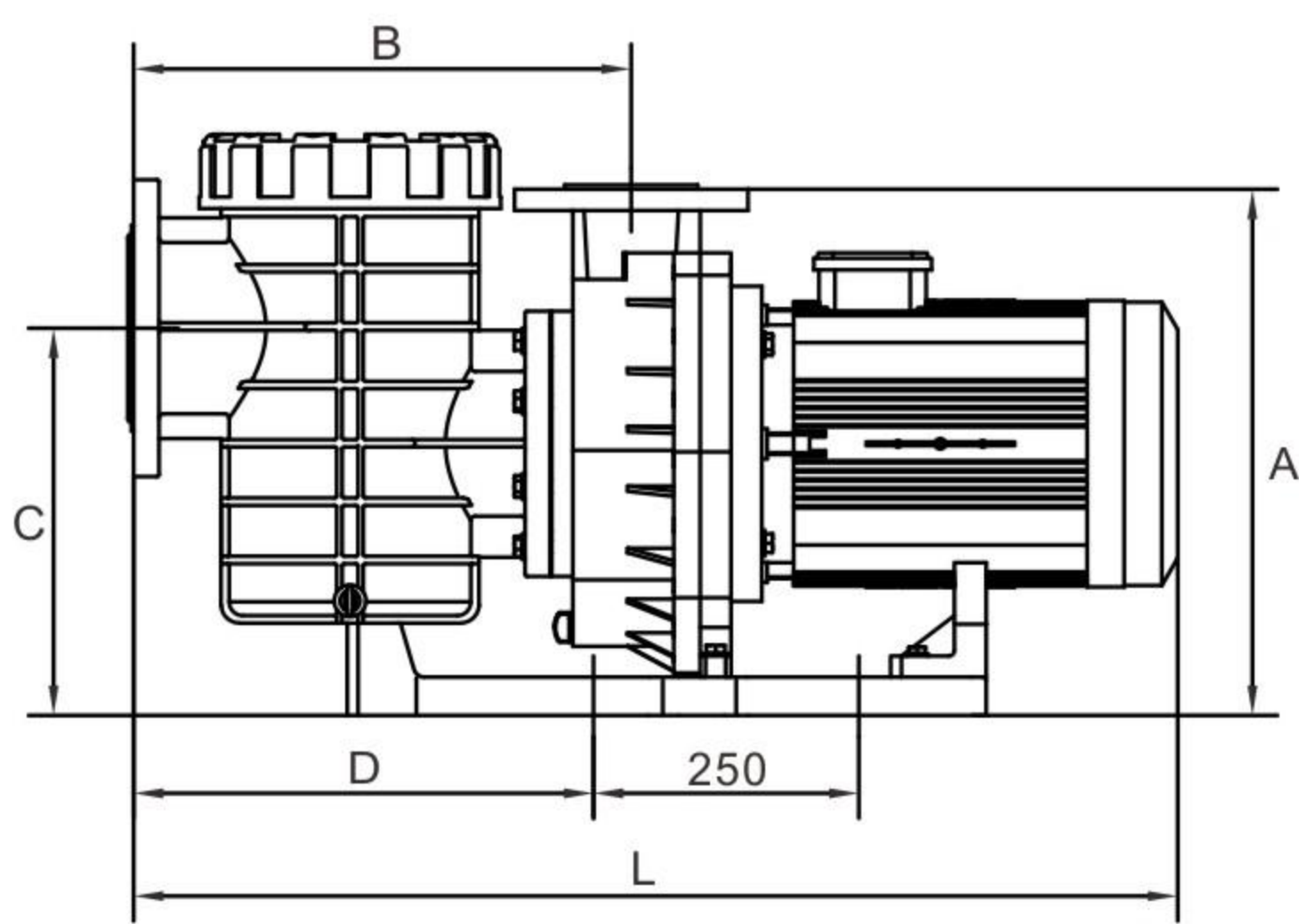

Model	Voltage	Power		Inlet	Outlet	L	A	B	C	D
	(V)	(KW)	(HP)							
ALBsalt-550	380V/50Hz	4.0	5.5	DN125	DN80	810	481	441	365	402
ALBsalt-750	380V/50Hz	5.5	7.5	DN125	DN80	830	481	441	365	402
ALBsalt-1000	380V/50Hz	7.5	10.0	DN150	DN100	930	496	469	365	433
ALBsalt-1250	380V/50Hz	9.0	12.5	DN150	DN100	930	496	469	365	433
ALBsalt-1500	380V/50Hz	11.0	15.0	DN150	DN100	970	496	469	365	433
ALBsalt-2000	380V/50Hz	15.0	20.0	DN150	DN100	1040	496	469	365	433

★ 110V/220V/380V,50/60Hz pump can be customized.