



# AQUARIUM SERIES FILTER PUMPS

## ABsalt



- IP55 waterproof standard.
- Big flow rate.
- Maximum working pressure up to 6 kg/cm<sup>2</sup>.
- 316 stainless steel shaft.
- Graphite/ceramic mechanical seal.
- Suitable for maximum hot water temperature up to 70°C.



Suitable for sea water, working pressure up to **6 kg/cm<sup>2</sup>**.

### Specification and size:

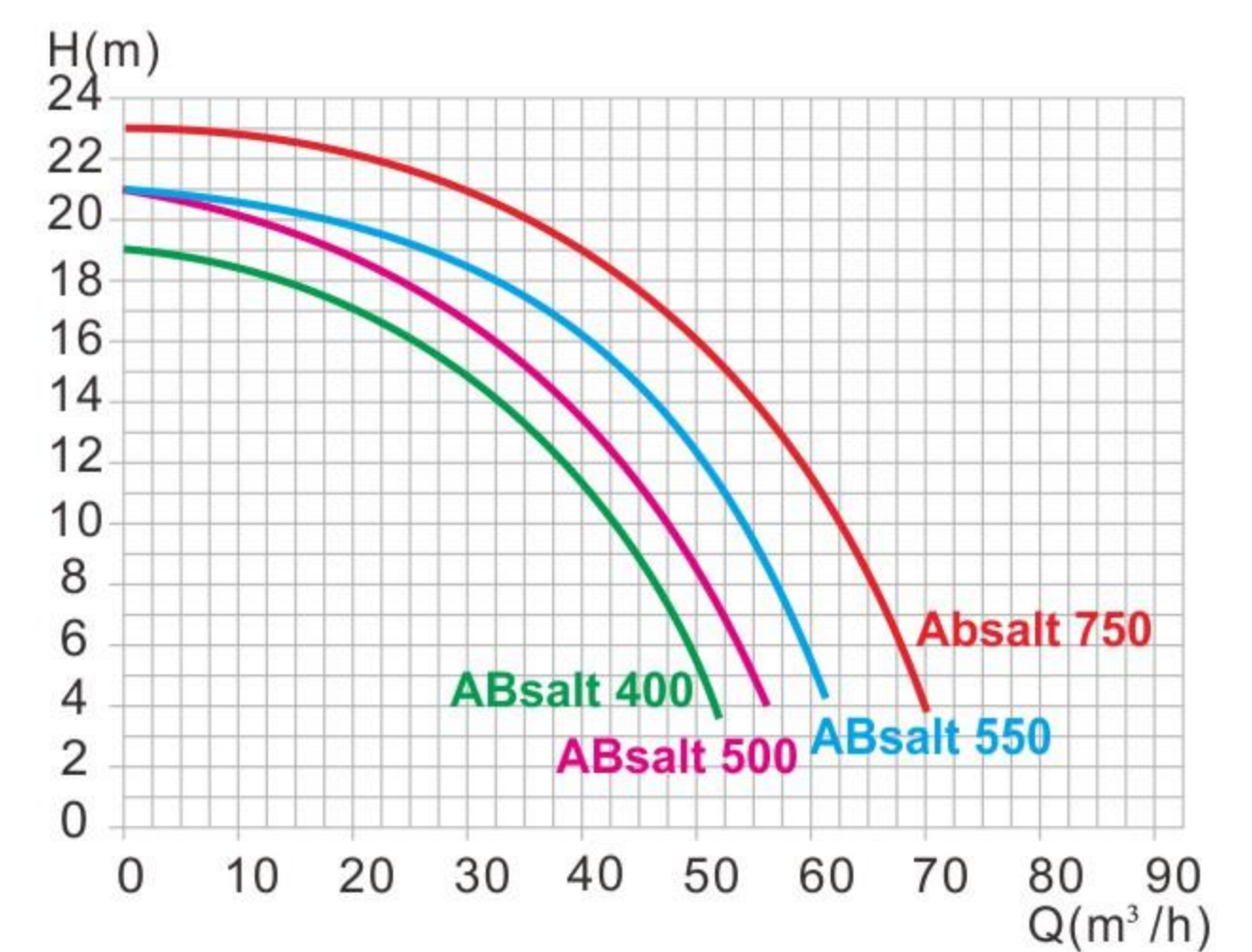
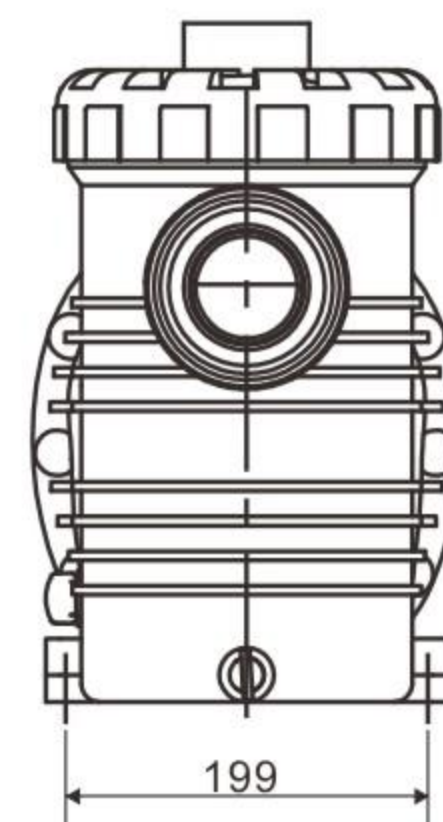
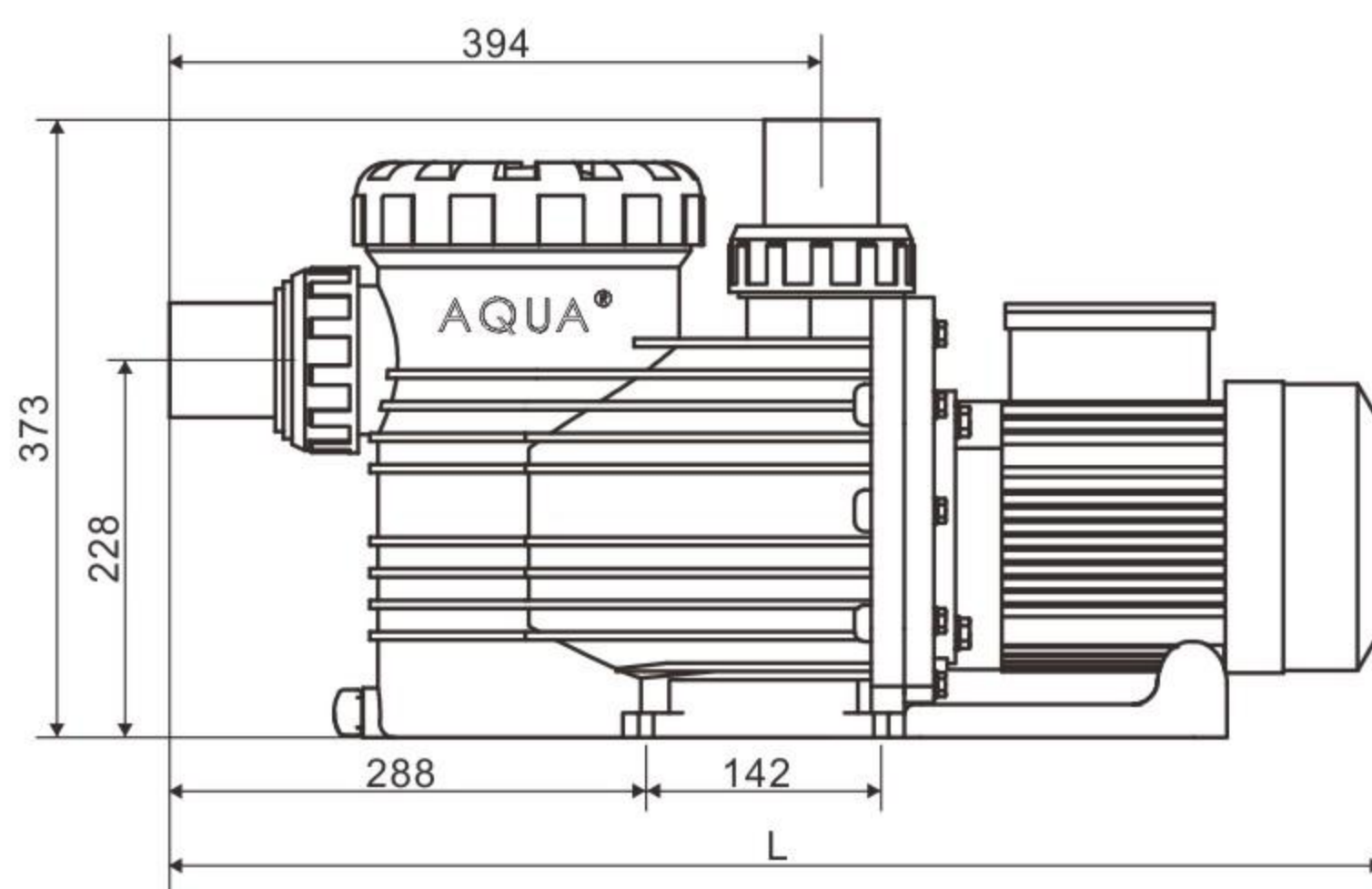

Model	Voltage	Connection Size	Output power	Rotational Speed	Length
	(v)		(kw)	(rpm)	(mm)
ABsalt 400	380V	DN65	3.0KW	2850	750
ABsalt 500	380V	DN65	3.8KW	2850	750
ABsalt 550	380V	DN65DN80	4.0KW	2850	770
ABsalt 750	380V	DN65DN80	5.5KW	2850	780

★ 110V/220V/380V,50/60Hz pump can be customized.