



# AQUARIUM SERIES FILTER PUMPS

## ABSsalt



- Internal innovative design with big suction power.
- Simple design basket, easy to take out and install.
- Ultra quiet and IP55 motor.
- Come with two standard DN40 unions easy to install.
- Special materials are used. With superior pressure up to 6kg/cm<sup>2</sup>.
- Suitable for maximum hot water temperature up to 70°C.
- Tailor-made impeller and mechanical seal, suitable for long time use.



Appearance and design patented, counterfeiting not allowed!  
 Patent No.: CN201930303377.8

Suitable for sea water, working pressure up to **6 kg/cm<sup>2</sup>**.

### Specification and size:

### 技术参数及产品尺寸

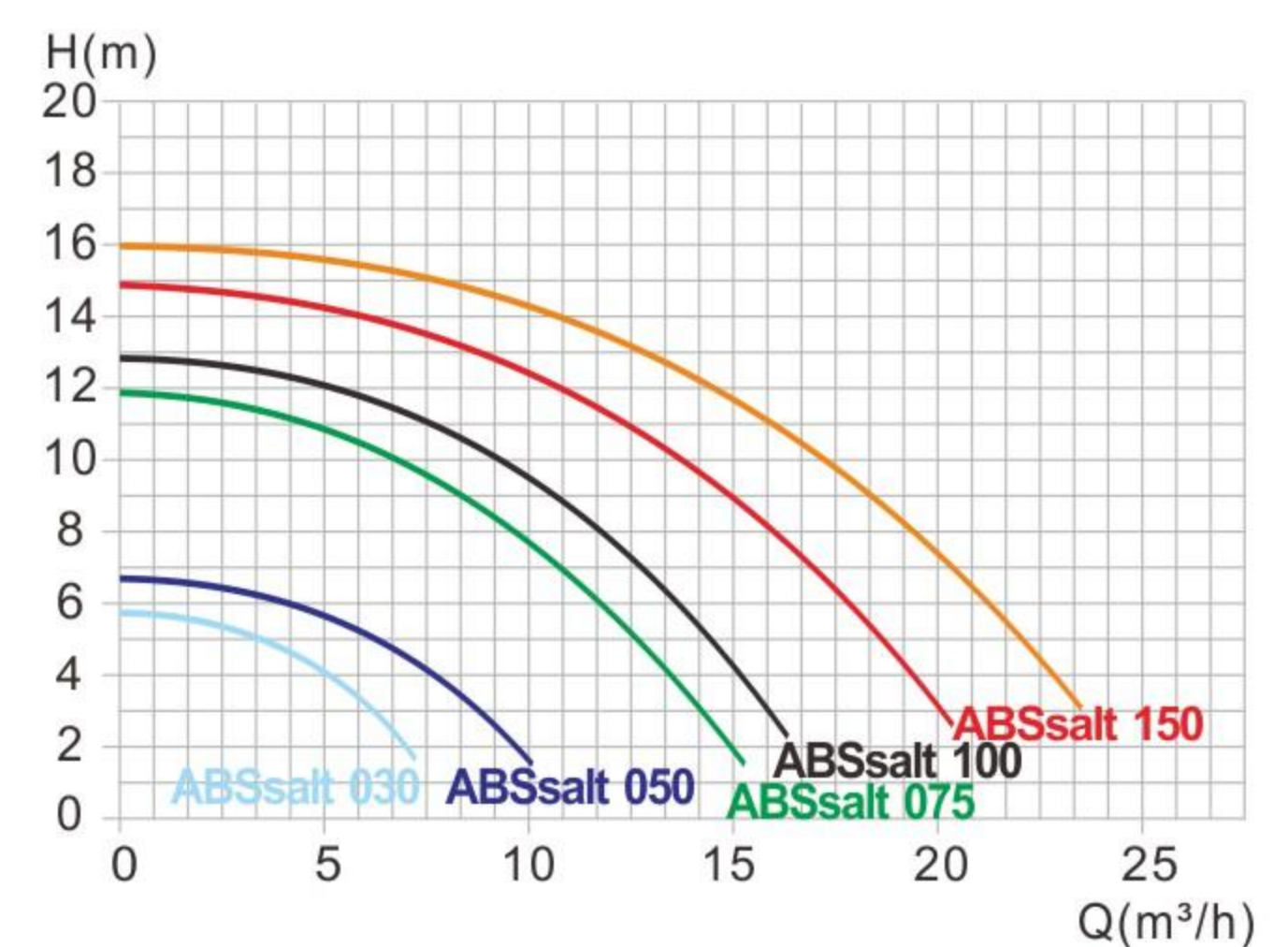
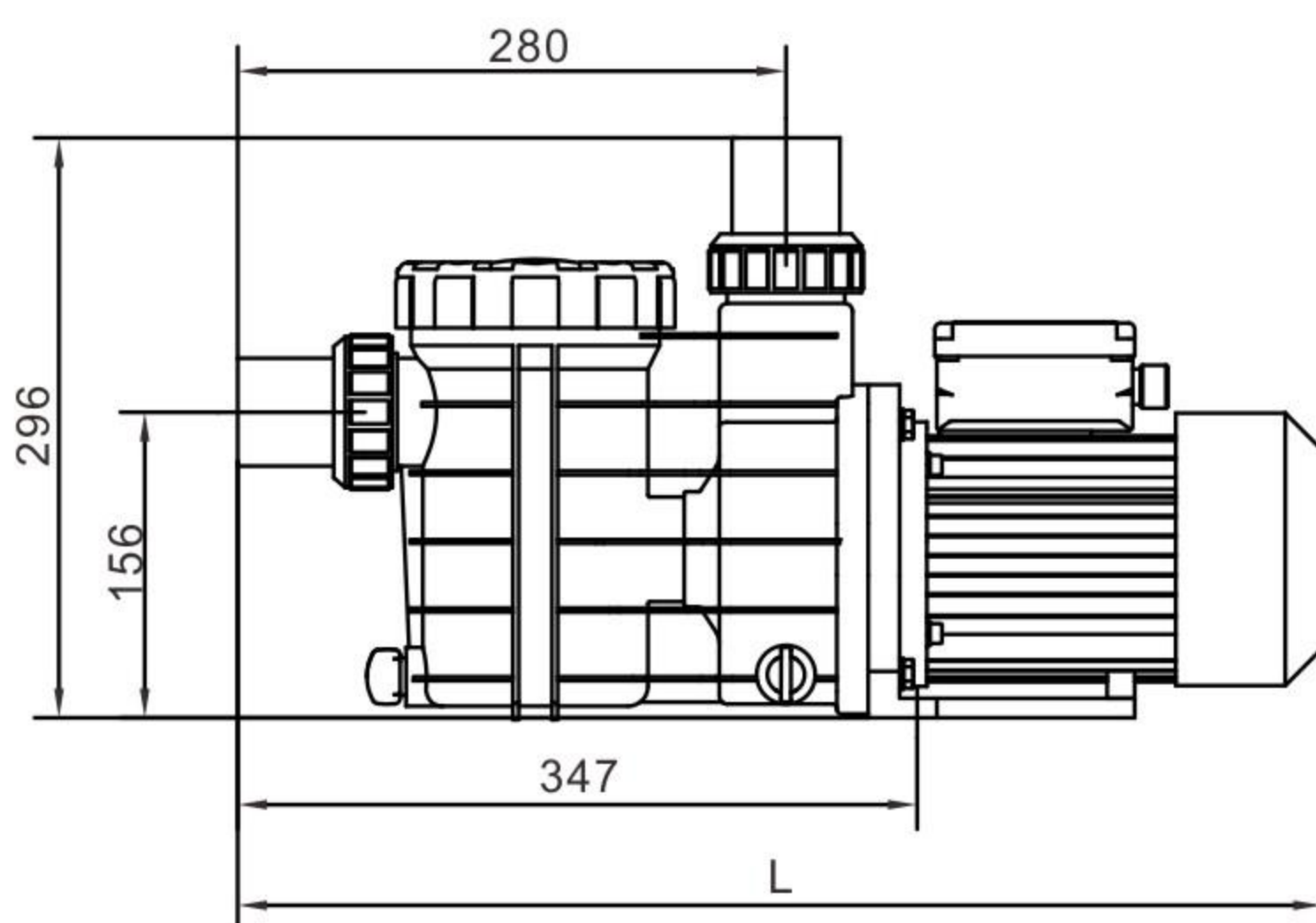

Model	Voltage	Power		Inlet/Outlet	Hmax	Qmax	Length	Width	Height
	(V/Hz)	(kW)	(HP)						
ABSsalt-030	220/50	0.25	0.3	DN40	6	7	500	168	245
ABSsalt-050	220/50	0.37	0.5	DN40	7	10	500	168	245
ABSsalt-075	220/50	0.55	0.75	DN40	12	15	500	168	245
ABSsalt-100	220/50	0.75	1	DN40	13	16	500	168	245
ABSsalt-150	220/50	1.1	1.5	DN40	15	20	500	168	245

★ 110V/220V/380V,50/60Hz pump can be customized.