



UV DISINFECTION DEVICE



PM

- Original imported UV lamp, Service life up to 10000 hours.
- High transmittance quartz tube.
- Ballast (more than 5 years service life, with a warning indicator).



- High-strength plastic housing.
- With electric control box.
- Two options: Vertical installation or horizontal installation.

Specification and size:



Union



Water Proof And UV Resistant Control Box

Compound Mode



Horizontal



Vertical

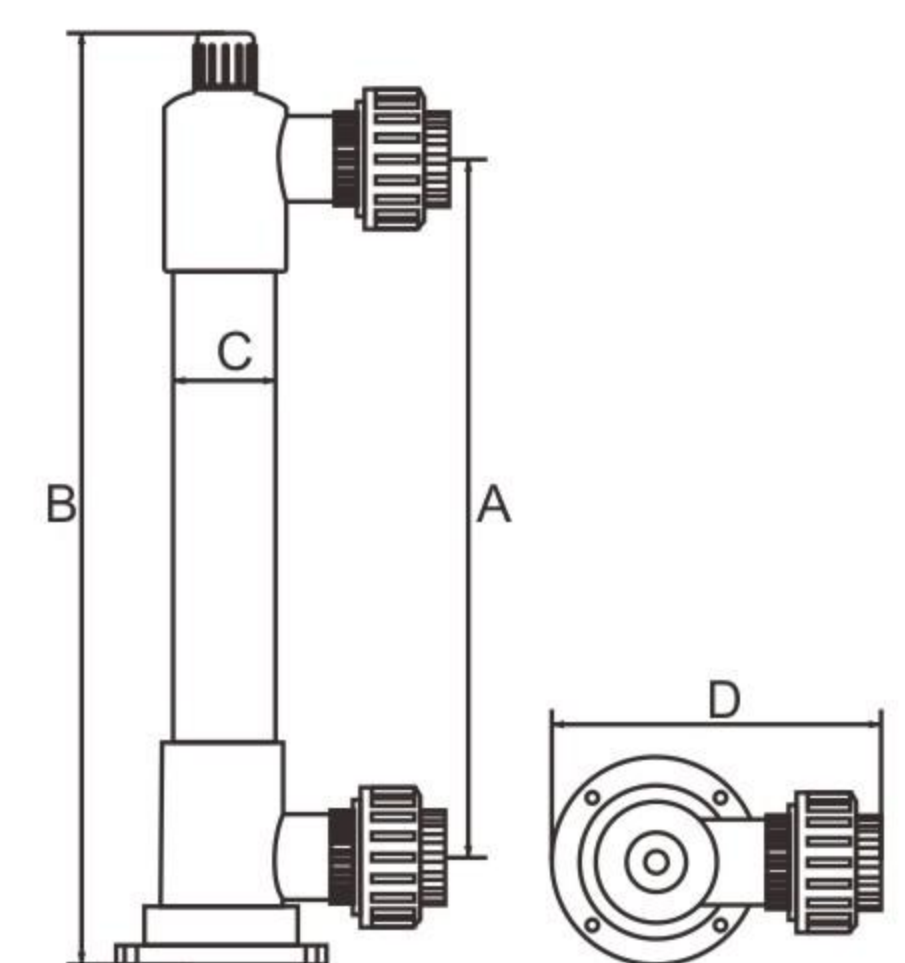

| Model | Voltage | Working Pressure | Flow | UV Lamp Power | Connection Size | Operating Temperature | Dimensions A/B/C/D |
|--------|---------------|-----------------------|---------------------|---------------|-----------------|-----------------------|--------------------|
| | (V/Hz) | (kg/cm ²) | (m ³ /h) | (W) | (寸) | (°C) | |
| PM-III | 100~240/50~60 | 2.8 | 18 | 87 | DN50 | 2~40 | 743/970/114/284 |
| PM-IV | 100~240/50~60 | 2.8 | 23 | 120 | DN50 | 2~40 | 1038/1265/114/284 |