



HIGH PERFORMANCE AIRBLOWER



AAP

- Shaft seal with fluorine plastic or imported skeleton maintenance-free shaft seal isolation motor.
- The electrical motor is squirrel cage motor with IP54 protection, Level B insulation.
- Vibration-absorbing baseboard, can reduce vibration.
- The motor adopts die-cast aluminum housing, heat dissipation fast, light weight.

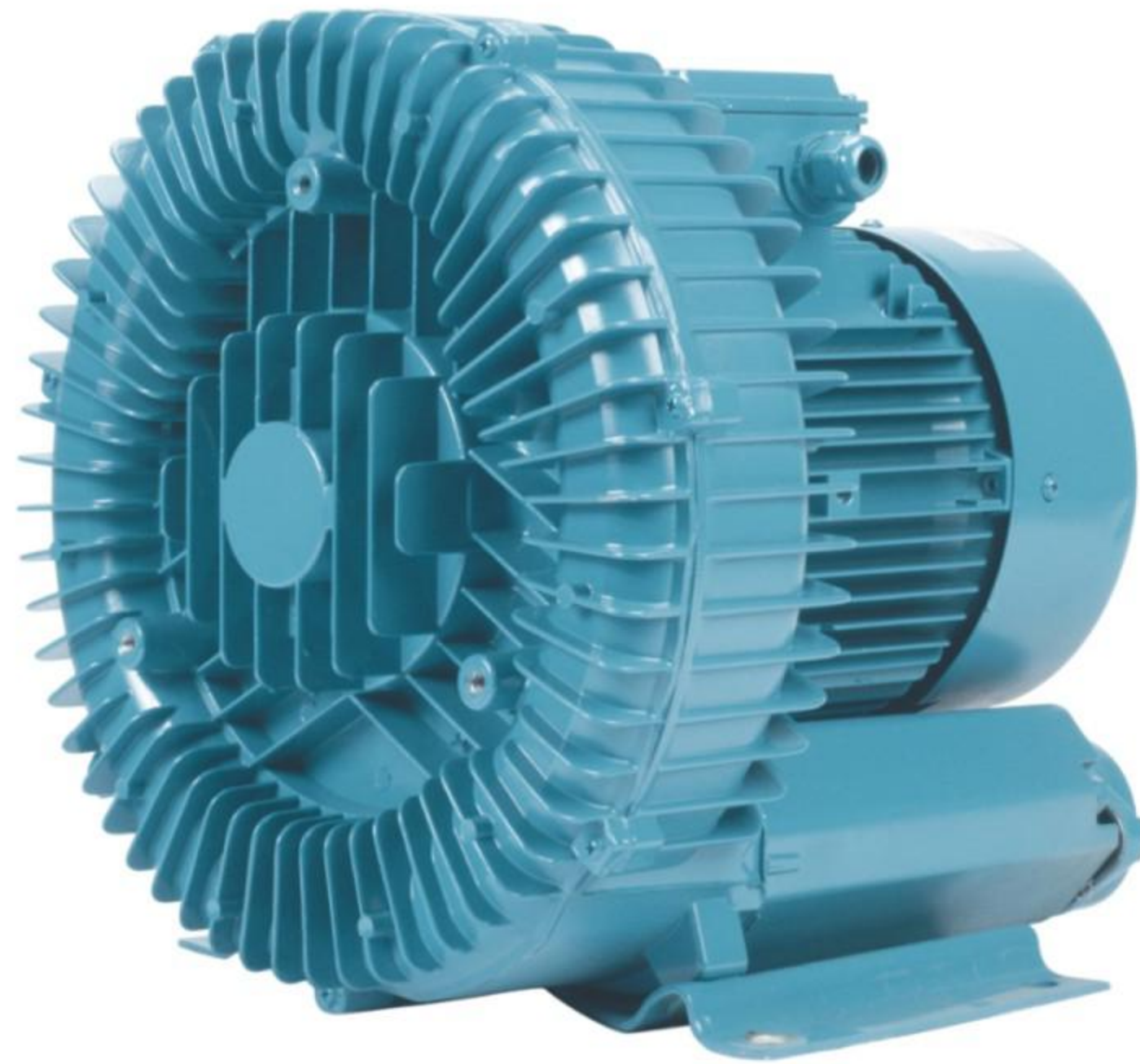

- The impeller is side-stream high efficient aluminum metal impeller.
- The surface of the cavity of the air pump was coated with anticorrosive paint, extend its life cycle.
- This product is suitable for various swimming pool and SPA pool.

Installation legend:

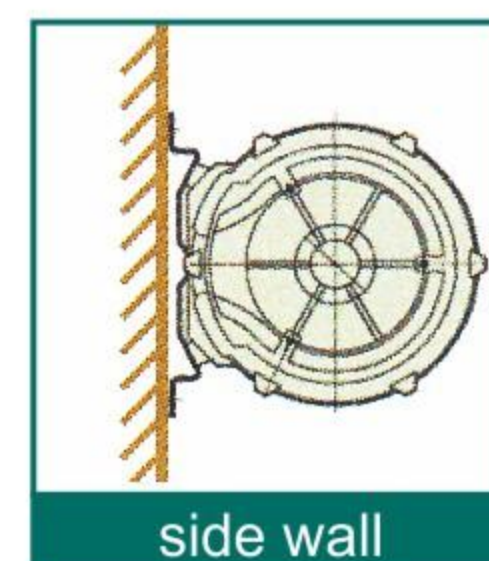
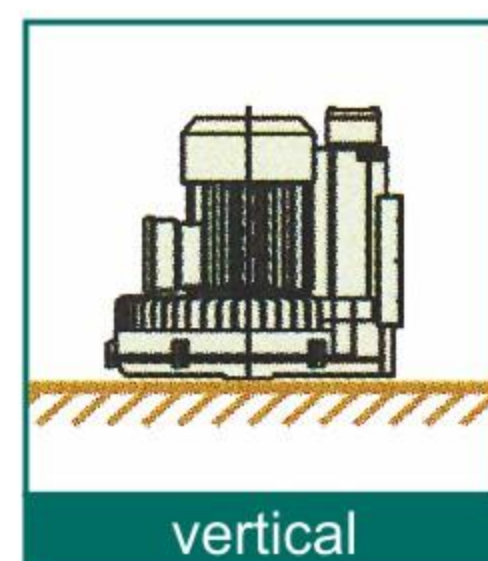
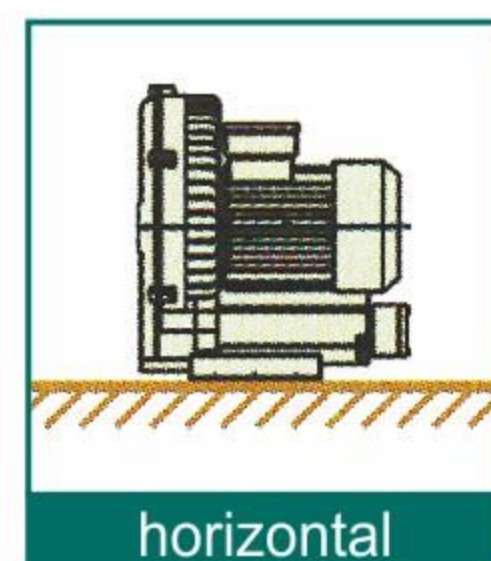

Specification and size:

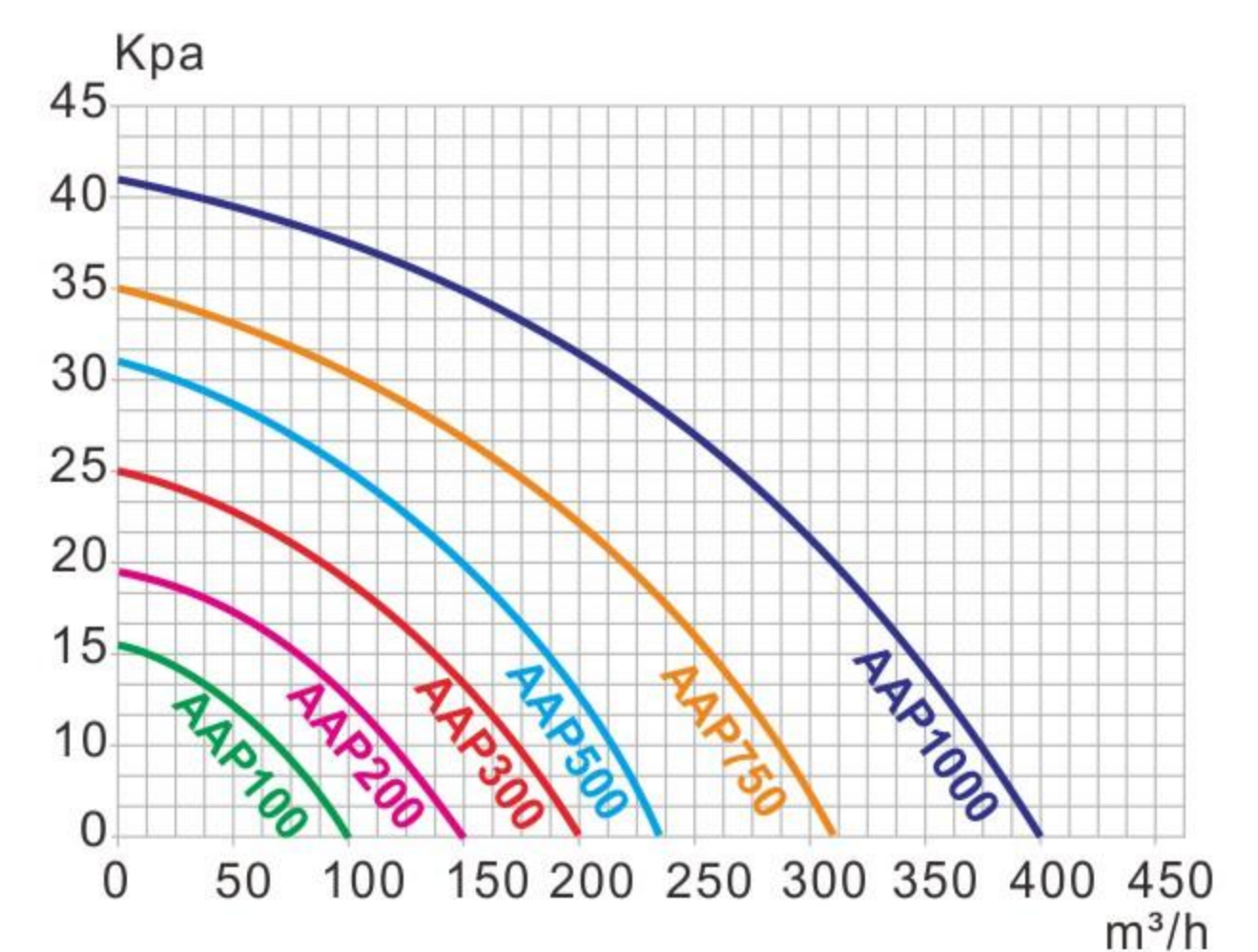
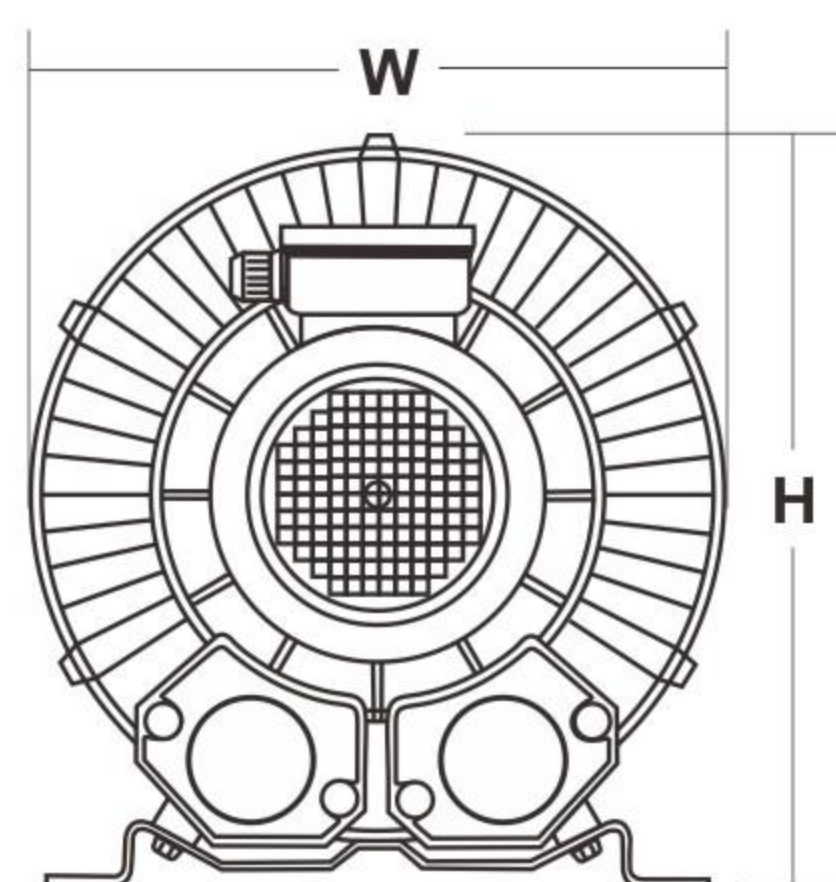
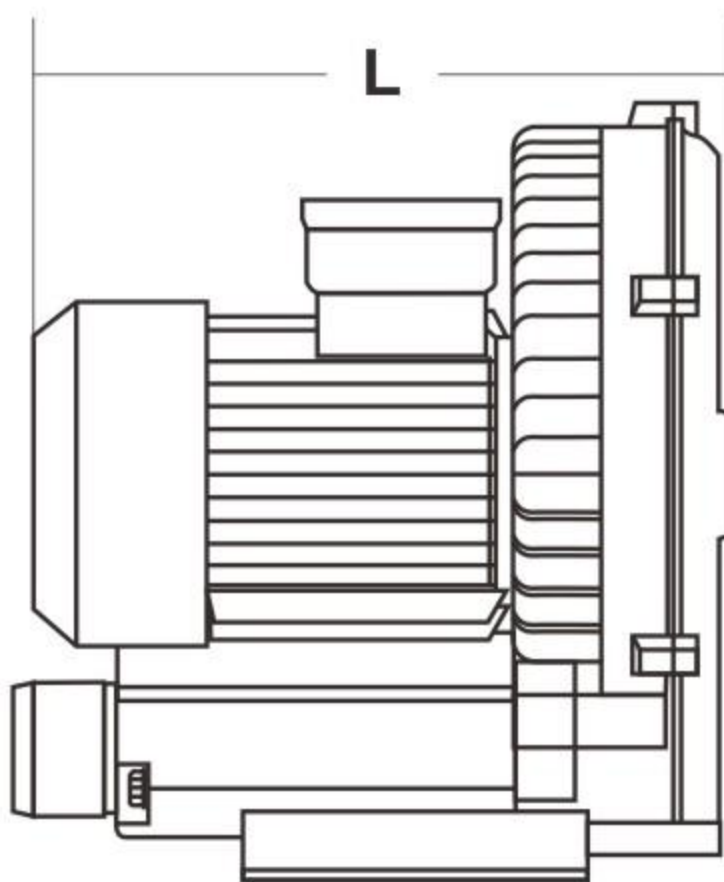

Model	Horsepower	Voltage	Max Pressure	Normal Pressure	Max Air Flow	Weight	Length	Width	Height
	(HP)	(V)	(Kpa)	(Kpa)	(m³/h)	(Kg)	(mm)	(mm)	(mm)
AAP-100	1	220	16	11	100	12.5	294	288	315
AAP-200	2	220	19	14	150	14.5	294	288	315
AAP-300	3	380	25	16	200	33	345	360	371
AAP-500	5	380	32	23	235	37	401	384	403
AAP-750	7.5	380	35	26	320	65	410	392	404
AAP-1000	10	380	42	31	400	121	472	418	453