



# PROFESSIONAL SWIMMING POOL PUMP



## ATS

## AT

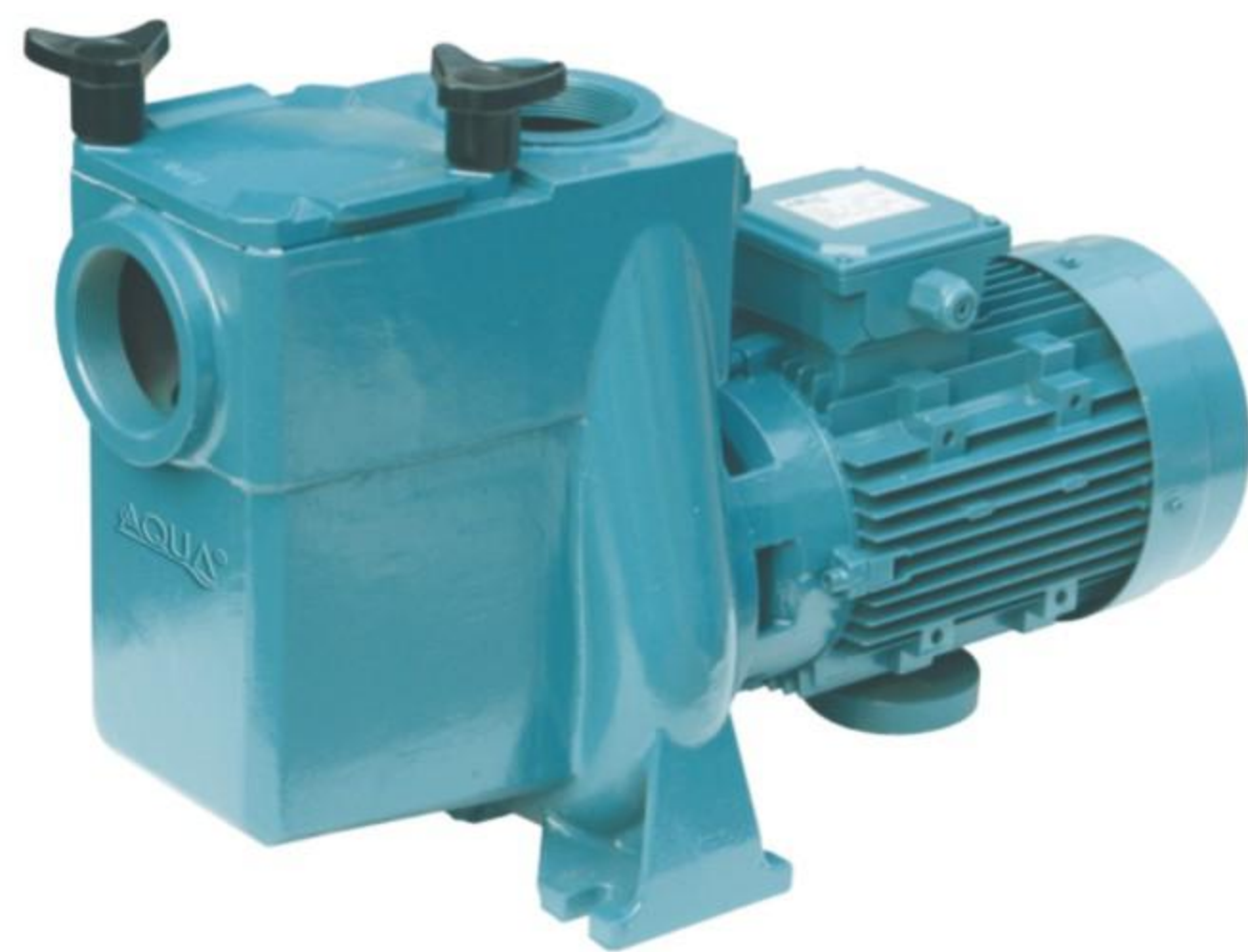

### Operating conditions

Liquid temperature up to 60°C.  
Ambient temperature up to 40°C.  
Maximum self-priming lift up to 2 m.  
Maximum working pressure up to 6 bar.

### Motor

2-phase induction motor, 50 Hz, 2900 rpm.  
400V  $\pm 10\%$  from 2.2 to 11kW.  
Insulation class F.  
Protection IP54.  
Constructed in accordance with IEC 34.



High temperature resistant tooth flange (optional)



Impeller  
AISI 304 stainless steel

## Specification and size:

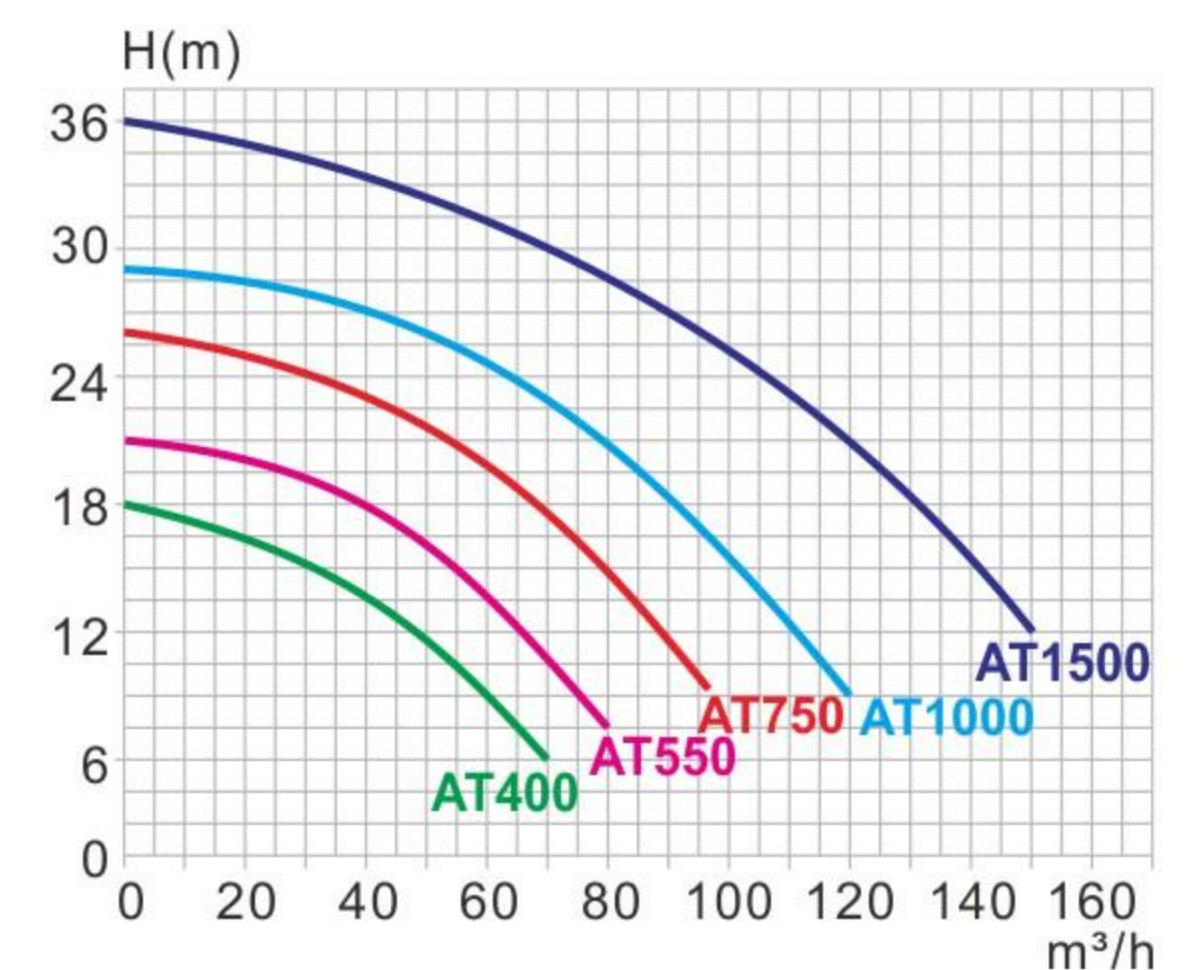
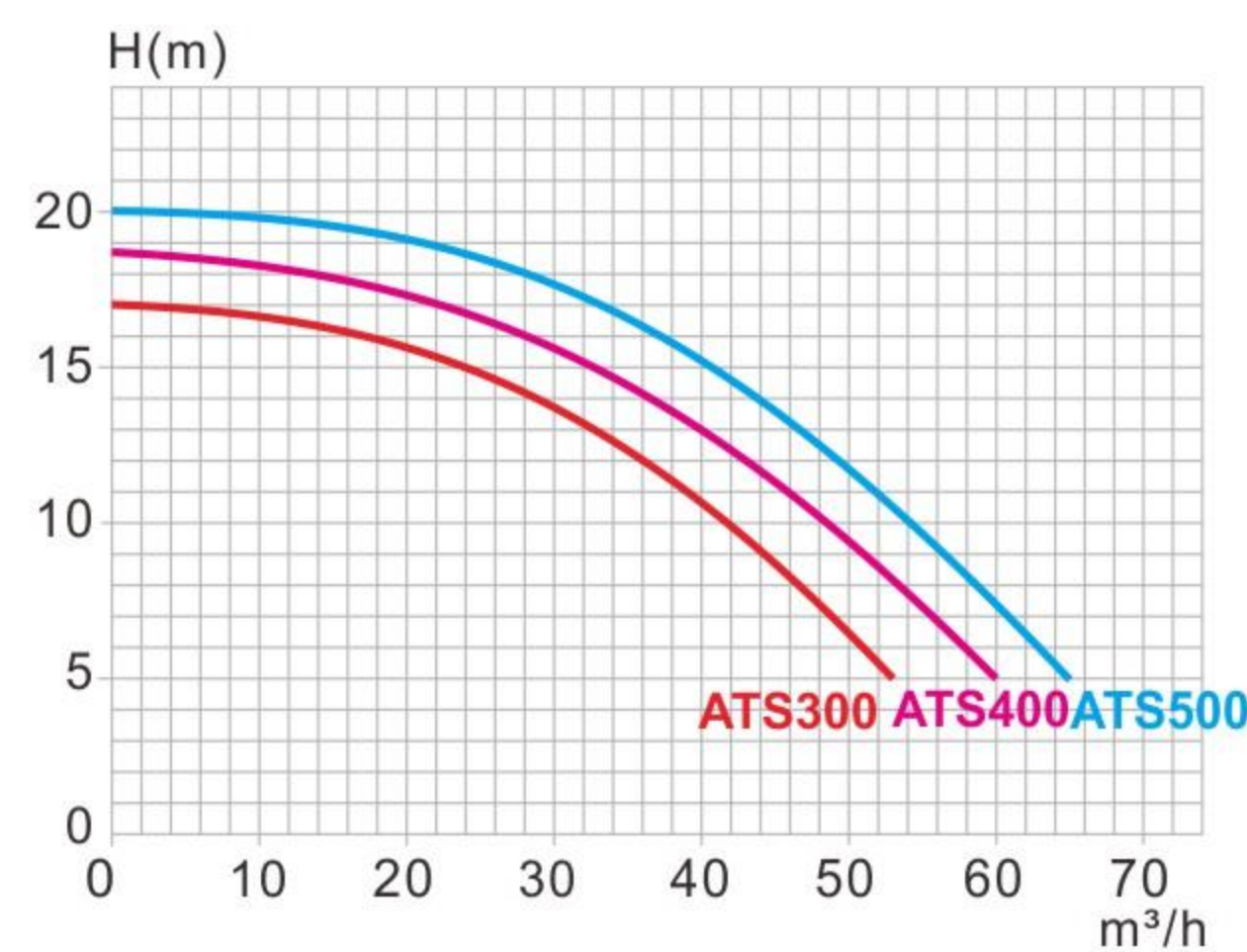
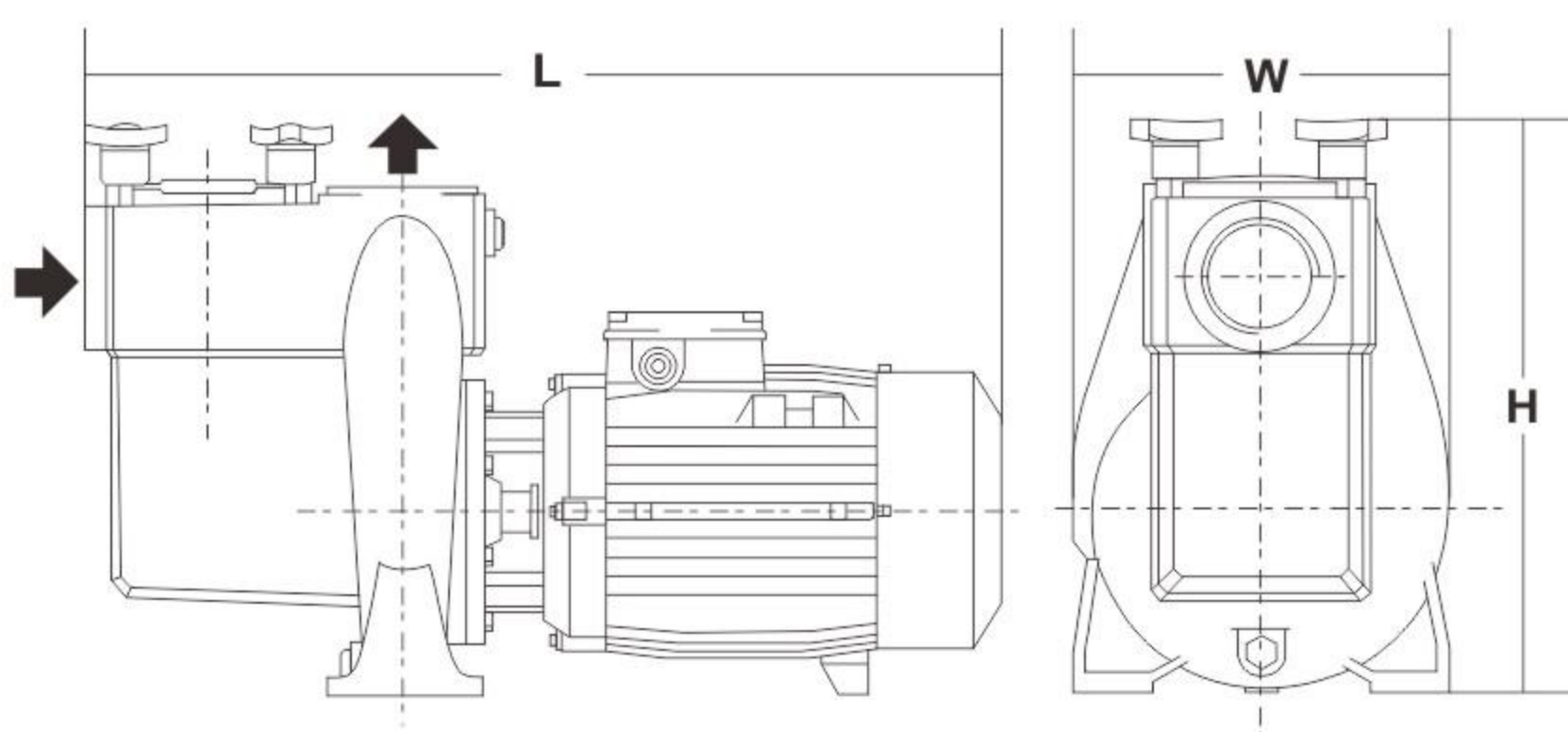

Model	Voltage	Connection Size	Power	Weight	Length	Width	Height
	(V)						
ATS300	380	DN65	2.2	46.0	597	262	360
ATS400	380	DN65	3.0	48.0	597	262	360
ATS500	380	DN65	3.8	49.0	597	262	360
AT400	380	DN80	3.0	93.0	715	332	472
AT550	380	DN80	4.0	95.0	715	332	472
AT750	380	DN80	5.5	100.0	750	332	472
AT1000	380	DN80	7.5	110.0	860	332	472
AT1500	380	DN80	11.0	115.0	860	332	472